

THE RESULTS OF MEASUREMENTS OF STRETCH WITH THE DIFFERENT TYPES OF STAYBOLTS

Von Dr. Ing. Arnold Tross

Translated By: Inge von Kehl, Clinical Toxicologist, ret.

Edited by: Cynthia Meister, M.S. English Literature

Matt Janssen, Foreman, Wasatch RR Contractors

2006

In order to certify the correctness of the theoretical concepts of those in the May and July published issues, experiments were conducted at the technical institute at Stuttgart regarding the behavior of the changes of the different forms of the staybolts under conditions of pure bending. As far as the influence of the various staybolts is concerned, the results are available.

The already described shapes of the four previous forms in the earlier publication:

- 1) BgD 18 - Staybolts with uniform diameter 18 mm;
- 2) BDR 28.5/18 Staybolts of the Deutsche Reichsbahn with 28.5 mm head, 18 mm diameter of the shaft, 25 mm conus;
- 3) BTH 28.5/18 Staybolts of Tross-Henschel type with 28.5mm head, 18 mm diameter and a special fitted conus length;
- 4) BgW 28.5/18 Staybolts with the same degree of resistance against bending, with the same parabolic shaped bolt replacement for the selected experimental conditions that correspond to a carrier of the same bendability.

With the shaping of the BTH the shift of the turning point along the line of bending needed special considerations because of the unequal strength of the firebox and the boiler wrapper as well as other aspects. For these reasons the BTH is better suited for the conditions in the boiler while only the symmetrical s-shaped bending as in the BgW yielded the most favorable values from the experiments.

The purpose of the studies was to observe the effects of changes of the form over the length of the four different types of staybolts under elastic conditions as well as at the beginning of the plastic phase according to the bending directions f_b to the maximum of 12 mm. The experimental pieces had been machined from St C 10.61 a material with a certain fluidity in order that all types of bolts are covered, and the head attachment in all cases to be considered as unyielding. Measurements were taken for all load conditions and stretches at various distances for the stays, also the top and bottom side of the staybolts. For measurements of stretch, resistance wire (strain-gauges) from the company

of Huggenberger with 5 mm marks were used. With this method the maximal stretch of the measurements was 2.5%, with greater stretching the glue failed.

The applied force was equal to a symmetric s-forming bend. All experimental pieces had the identical bending length L_s of 150 mm.



Abb. 1. Örtliche Dehnung des BgD 18 bei zunehmender Belastung



Abb. 2. Örtliche Dehnung des BDR 28 bei zunehmender Belastung

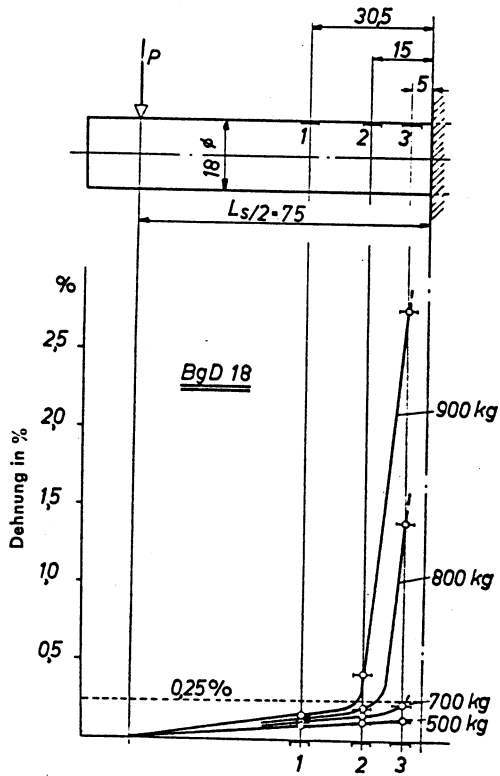

Abb. 3. Örtliche Dehnung des BTH 28 bei zunehmender Belastung

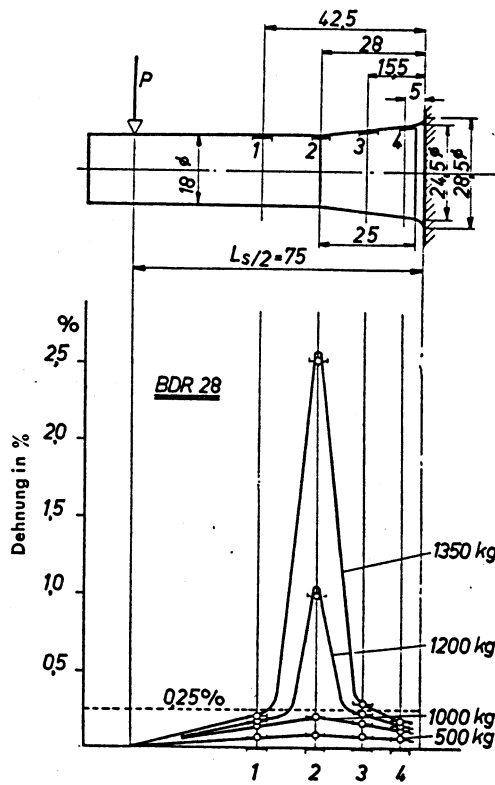

Abb. 4. Örtliche Dehnung des BgW 28 bei zunehmender Belastung

In the Illustrations 1-4 the results of the measurements of stretch for every one of the halves of the four experimental staybolts are shown. Also in the upper illustration, one finds a half staybolt with indications for the measurement point, the lower illustration expresses the proximal movement of stretch with different forces and length of bending. The strain gauges which had been applied to the first experimental pieces at the pressure and pull sides yielded no differences in the stretch yield, therefore with the following experimental pieces the pressure aspect was ignored.

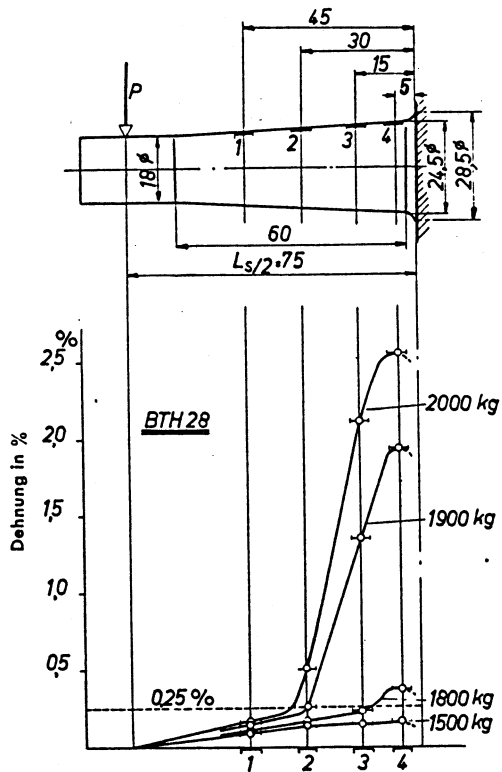
The 5 mm long level lines in the upper and lower part of the illustration correspond to the length of the part that yields, which is the length of the heights of those parts. That yield gives the average value of the measured distances. The real stretch points are partially higher in comparison with the measure of the maximum stretch.

Therefore it is important that one considers the microscopy of the building materials ability to flow as a result of the jolt like quantitative flow-ability. There are no stretch values between the stretch limit (aprox. 0.1% stretch) and the beginning of the strain gauge attachment (approx. 3% stretch.) Using microscopic consideration concerning the length of 5 mm, one will obtain in the illustration the average stretch values of 0.1 to 3%.

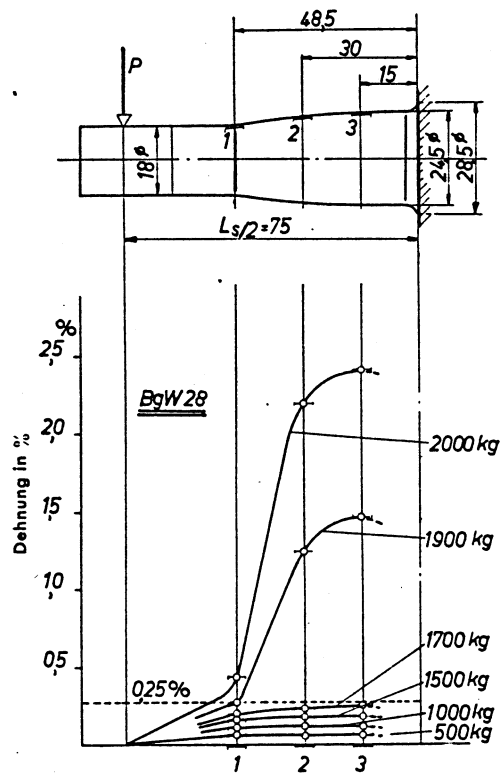
A study of the Illustrations 1-4 will give the approximate picture of the stretch values for the free bending length with various steps of loads for the four stays, where one can observe the course to be near the dangerous cross cut as indicated by the stippled lines. The rounding-up and the consequential conditional crosscut strengthening affects the results of the measurements at the point of the attachment.

In the area of the elastic aspect, the stretch and tension curves are corresponding respectively. However, if in a case of the exterior fiber stretch value of 0.25% is exceeded, the corresponding crosscut will begin to flow until its attachment affects the values. This observation is in line with the support value of the interior fibers of the experimental work at the starting point of the local fibers. The obtained value of 0.25 % as the upper limit is in agreement with the theoretically obtained buckling point in Illustration 20 c section 2¹.

If the stretch limit of the deeper more central fibers has been passed, one will observe the formation of flow-wedges which will lead to stretches at the surface that may exceed the 5 mm limitations to a greater degree.

In the case of the BgD and BDR in the area of the plastic part one can observe definite stretching points according to Illustration 1 and 2. Regarding the BTH and BgW with the same crosscut measure and identical attachment length the local flow is observed when the load will be 60, that is 140%, (1900 kg. in contrast to 1200 that is 800 kg.) higher in the case of the BDR in comparison to BgD. Furthermore, no stretching point is notable, over a broad area the flow-tension appears simultaneously. The “plastic link” appears as expected much clearer if the increase in tensions is much steeper.

¹ July Booklet 1952, S. 156.



Abb. 5. Belastung der 4 Vergleichsbolzen in Abhängigkeit von der Maximaldehnung



Abb. 6. Belastung der 4 Vergleichsbolzen in Abhängigkeit von der Bolzendurchbiegung

In Illustration 5 the relationship of the load regarding the stretch in the dangerous crosscuts and in Illustration 6 total bending of one of the four staybolts is observable. As soon as the crosscut begins to flow, the buckling point and maximal stretch increase rapidly. The starting point for the flow for BTH and BgW is considerably higher than it is for BgD and BDR. The curves show the high permitted shape change force of the BTH² consequently indicate that the staybolt's strength is increased when applied to the rear-boiler and as a result a greater strength overall will be obtained.

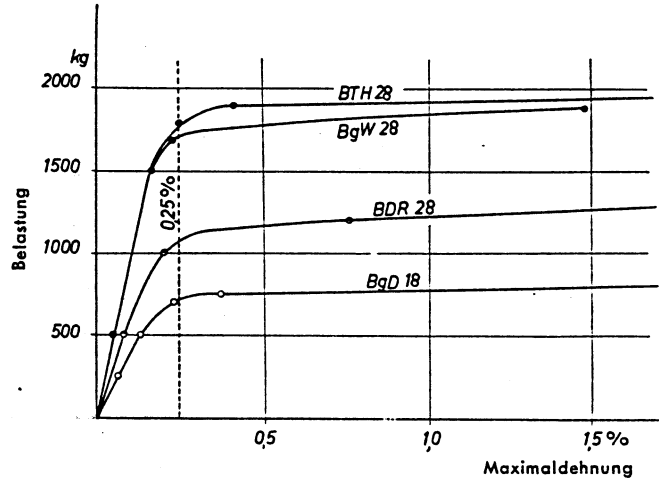
Even when the bending direction for all stays is equal, an advantage is nevertheless with the newest type of construction. This can be seen in Illustration 7 where the measured stretch of the most stretched length with dependence on the total bending of the stays is shown.

² Vgl. Abb. 29 in "NEW KNOWLEDGE AND CONSTRUCTION DIRECTIONS IN THE AREA OF THE LOCOMOTIVE REAR BOILER (STAYBOLTS, FIREBOX, AND BOILER)"

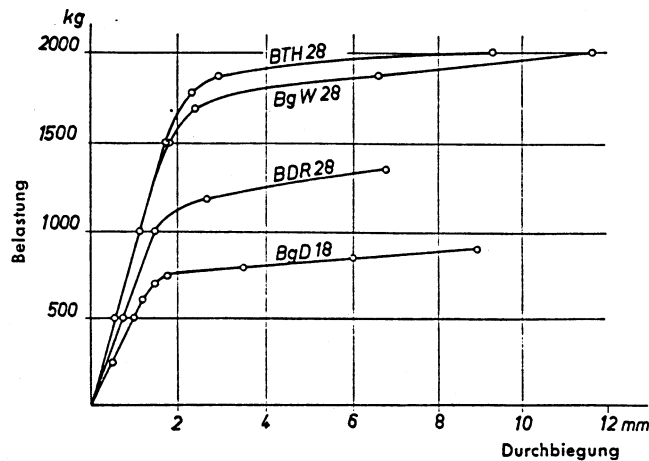
The significance of the 0.25% limit at the beginning of the local flow can be observed in Illustrations 1,2,3,4,5 and 7 where the limits are clearly indicated. The buckling point of all the illustrated stretch-curves is in close proximity at the point of intersection of these curves at the 0.25% line.



Abb. 7. Örtliche Größtdehnung mit zunehmender Bolzen-
durchbiegung

²⁾ Vgl. Abb. 29 in „Neue Erkenntnisse und Konstruktions-Richtlinien auf dem Gebiet des Lok-Hinterkessels (Stehb., Feuerbüchse, Stehkessel)“

The peculiar curving in Illustration 7 is related to the clearly expressed flow area depending on the kind and type of building material utilized. After passing the 0.25% limit the stretch increases more rapidly than the bending flex and only with the increasing effect of the stabilization will the values for the bending flex rise.

In summary the results of the strain-gauge measurements can be expressed in the following manner:

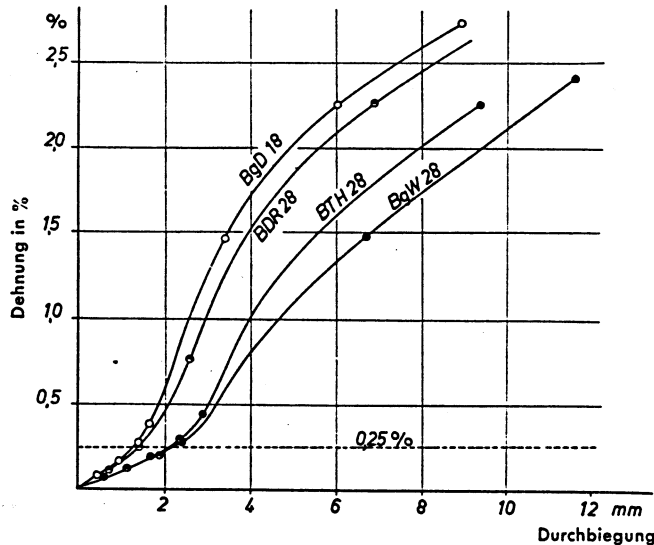
- 1) In the elastic area there is correspondence between the stretching-curves to the tension-curves.
- 2) A locally stronger flow does not start with the stretch limits of the exterior fiber, but rather as a consequence of the support of the interior fibers which have not yet reached the stretch limit of about 0.25%.
- 3) In the case of staybolts with a particular tension point like BgD and BDR, after passing the 0.25% limit, one will note plastic links in the area of the tension-points.
- 4) The load limits of BgW and BTH are 66% higher than in the case of the BDR and 150% higher when compared to BgD.
- 5) The maximal stretch in the case of a bending direction (arrow) is 4 mm; in the case of the BTH there is about 50% less in comparison to the BDR and 70% less than the BgD. In the case of the BgW the values are correspondingly 87% and 114% less. With consideration of the decreased bending of the BTH as a

- consequence of the larger strengthening by reinforcements of the rear boiler, the differences may be greater.
- 6) The experimental results are in agreement with the effectiveness of the BTH staybolt as observed in actual operations. This is a consequence of the ideal conditions for the BTH staybolt in the area of the plastic material employed.

NOTE: Concerning the effects of the type of building material used, the sagging curves and the stretching curves will be published after conclusion of other experiments.